

WESTERN UNDERGROUND COMMITTEE

GUIDE 3.6 (3.6/02/0588)

NONCONCRETE ENCLOSURES

NOTE: This "Guide" summarizes the opinions, recommendations, and practices of the Western Underground Committee members and is issued only to assist these members in preparing their own specifications, or in making recommendations to specification agencies. Thus, this "Guide" may not reflect the complete requirements of each individual utility and is not binding upon them.

1.0 SCOPE

- 1.1 This guide covers the requirements for non-concrete enclosures. Standard sizes are indicated in Section 4.1 and Figures 1 to 4, (pages 12 to 14), enclosure component dimensional requirements.
- 1.2 It includes standard sizes, design criteria, appearance, and performance tests.

2.0 GENERAL

- 2.1 One traffic rating is covered by this guide:
 - a. Incidental traffic – Enclosures suitable for incidental vehicular traffic for installation in light commercial and residential sidewalks and behind curbs where no deliberate vehicular traffic is planned.
- 2.2 Enclosures shall be designed and suitable for installation and use through a temperature range of -40°C to $+90^{\circ}\text{C}$.
- 2.3 Exposed portions of the box and cover shall have a high coefficient of friction (COF) surface. The surface COF shall be a minimum of 0.50 over the enclosure and covers expected life and approved by the user.
- 2.4 The enclosure shall be available in both telephone green and concrete gray colors.

- 2.5 Covers shall be identified as to the ownership by an appropriate logo, initial, or name as specified by the user.
- 2.6 Covers shall conform to dimensions shown in figures 1 to 4 and be interchangeable with all other boxes of the same size manufactured to this guide.
- 2.7 Covers shall be provided with a means to be fastened to the box such that a tool shall be required for their opening and removal. Location for such devices shall be as shown in Figures 1 to 4. Such devices shall be made of a non-corrosive material. Such devices shall withstand minimum torque and pullout strengths as specified in Section 5.2.4.
- 2.8 Covers shall meet the flammability test per Section 6.2.7. A spray or paint covering to achieve the required nonflammability is not acceptable.
- 2.9 Covers shall be resistant to ultraviolet radiation per Section 6.2.5.
- 2.10 Boxes and extensions shall conform to dimensions shown in Figures 1 to 4 and be interchangeable with all other boxes of the same size manufactured to this guide.
- 2.11 Boxes and extensions shall meet the flammability test per Section 6.2.7. A spray or paint covering to achieve the required nonflammability is not acceptable.
- 2.12 Boxes and extensions shall be resistant to ultraviolet radiation per Section 6.2.5.
- 2.13 Boxes and extensions shall have adequate soil bearing surface to prevent settling in any soil, when tested in accordance with Section 5.1.
- 2.14 Knockouts shall be notched to provide a smooth edge upon removal for cable entry. Knockouts will be supplied in the extensions only, 4" minimum conduit size. Exact size to be specified by user.

- 2.15 Top outer circumference of the box shall be provided with a method of keying the installed box to surrounding concrete that it may be placed in.
- 2.16 Enclosure shall be suitable for installation, either, direct buried in native soil, embedded in concrete, or embedded in asphalt surfacing.
- 2.17 When covers are fastened in place, the enclosure shall be secure, preventing entry of any foreign probes that might result in electrical contact with conductors, connectors, or other equipment.

3.0 DEFINITIONS

- 3.1 Handhole – Refers to the complete box, cover, and if provided, extensions and base.
- 3.2 Box – Upper main section of handhole containing a recess to receive the cover.
- 3.3 Cover – Top surface section of handhole for closing top opening of box section.
- 3.4 Extension – Lower section that may be used to increase depth of handhole.
- 3.5 Base – Floor section for closing bottom opening of handhole. May also be used to increase the depth.
- 3.6 Knockout – Portion of extension or base with reduced thickness or notched Outline-accommodating removal for entrance of cable or conduit.
- 3.7 Key to concrete – Method of interlocking top edge of box to surrounding concrete place for sidewalk.
- 3.8 Any area, any damage – That area or edge where load is most critical.

- 3.9 Pre-Load – Pre-Load shall be 5 percent of test load and shall be applied for a duration of 1-minute $\pm 1/4$, unloading in 1-minute $\pm 1/4$, and waiting 1 minute $\pm 1/4$ at zero load before proceeding with test.
- 3.10 Zero Load Deflection Readings – Readings taken at the beginning and end of the unloaded portion of the test cycle.
- 3.11 Permanent Deflection – The deflection difference between the start of testing (after pre-load) and the end of testing (end of tenth cycle).

4.0 DIMENSIONS

- 4.1 Enclosures shall be available in the following nominal ID dimensions:

	<u>Width</u>	<u>Length</u>	<u>Depth</u>	<u>Knockout Size</u>	<u>Extension Depth</u>
a.	13”	24”	18”	4”	8” & 16”
b.	17”	30”	18”	4”	8” & 16”
c.	24”	36”	18”	4” *	8” & 16”
d.	30”	48”	18”	4” *	8” & 16”

*These extensions may be fitted with duct terminators at the user’s request.

- 4.2 Extensions shall fit at the box bottom and align with the body at the maximum allowable deflection.

5.0 STRUCTURAL REQUIREMENTS

- 5.1 Enclosures shall be designed and tested to withstand the two classes of loading as listed below. A physical description of the testing methods shall be included with the test reports. Load versus deflection curves for both loading and unloading shall be provided.

- 5.1.1 Structural Tests

- a. Structural tests on enclosures shall be made using temperature ranges specified in Section 2.2, reports should be accompanied by manufacturer’s drawings with dimensions, including tolerances. The enclosure tested shall be certified as falling within the dimensions and tolerances shown on the drawings.

- b. After qualification (approval by the customer), the manufacturer shall make no changes in dimensions or material without submitting new tests for approval by the customer.
- c. All structural tests shall be preceded with a “pre-load”, see Section 3.9 for definition.

5.1.2 Incidental Traffic Loading – Enclosures shall be designed and tested for the following test loads:

- a. Cover – 10,400 pounds vertical load, distributed over 10” x 10” area. The load is to be applied with a 10” x 10” x ½” thick piece of rubber backed with a 1” thick steel plate. A spherical bearing swivel head shall be used in the testing machine. The cover will be mounted in a typical box during the test. The loading pad will be centered over the portion of the cover, which will produce the maximum deflection under load. Deflection measurements shall be taken perpendicular to the lid and wherever maximum deflection occurs. A deflection measurement device or devices will be positioned so as to measure only the deflection of the cover. The load must be cycled ten times, see Section 5.2.1.
- b. Box – Vertical Load – 10,400 pounds distributed over a 5” x 10” area. The same loading plates shall be used as in Section 5.1.2.a above. The base shall be fully supported with a rigid material. The horizontal axis of the loading pad will be centered on the long dimension and in the center of the box wall leaving approximately a 5” x 10” portion of the pad without contact. The tests shall be performed with typical cover in place. If extensions are to be qualified, the assembly must be tested with and without them attached. A deflection-measuring device shall be positioned to indicate lateral deflection wherever maximum deflection occurs. The load must be cycled ten time, see Section 5.2.1.

- c. Box – Lateral Load – NOTE: The relationship between the 10,400 pound vertical load applied to an area immediately adjacent to an installed enclosure and the resultant lateral force on the enclosure sidewall is dependant upon several variables. These variables include the type of backfill material, the amount of moisture in the backfill, the compaction of the backfill, the type of surface (earth, paving, etc.) around the enclosure, the design of the box, and others. Following is the lateral load test. The test should be performed at the designated bearing pressure (600 PSF). The enclosure should have a failure load of twice the test load.

Lateral Load – The bearing pressure, 600 pounds per square foot, shall be uniformly distributed and applied parallel to the top surface of the box on the wall with the longest dimension. The load shall be transmitted by a flat, rigid plate 24” wide by the depth dimension of the box, bearing against any suitable medium which will conform to the shape and angle of the box sidewall (such as air bags) to achieve a uniform reaction, or it may be supported on ribs or stiffeners so long as no local failure occurs. A swivel head will be used in the testing machine. A typical box cover will be installed for this test. For boxes with a long wall dimension of 24” or more, the loading plate will be centered on that wall. A deflection-measuring device will be positioned to measure the relative deflection between the testing machine table and the inside of the loaded sidewall of the box. If a compressible medium is used for a reaction base, its deflection shall be measured and subtracted from the total to yield the net deflection. If extensions are to be qualified, the assembly shall be tested with and without them attached. The deflection at the maximum allowable bearing pressure (600 PSF) shall be recorded. The test shall be repeated ten times to maximum allowable load and the corresponding deflection recorded see Section 5.2.1.

d. Deflection under design load shall not exceed:

(1) 1/2" for the cover.

(2) 1/4" per foot of length of box.

When the box dimensions are not uniform, an average of the minimum and maximum dimensions shall be used to determine the length used to calculate the allowable deflection.

5.2 In addition, all enclosures shall meet the following requirements.

5.2.1 Permanent deflection of any surface shall not exceed 10 percent of the maximum allowable static test load deflection. None of the cyclic loadings shall exceed the maximum allowable deflection. The cyclic loading shall be applied and removed at a uniform speed. After pre-load is applied, the full required load shall be applied, held, and removed within a three-minute period, then reapplied after a one-minute rest period. This cycle shall be repeated for the duration of the test. Deflection readings shall be recorded at a minimum of three increments during both loading and unloading of the first and last cycle (to include the point of maximum deflection). Permanent deflections shall be measured as soon as the load has been completely removed. In no case shall any permanent deflection of the cover, box, or extension be great enough to interfere with the placement or removal of the cover on the box or the box on the extension. After ten cycles on the lateral load test, the load shall be increased and the resulting deflection recorded at approximately 100 pound/square foot intervals, as far as practical with the deflection measuring devices used. The deflection measuring devices shall then be removed and the loading continued to failure. The ultimate load and mode of failure shall be reported.

5.2.2 Boxes, covers, extensions, and bases shall be capable of withstanding normal shipping and installation practices without chipping, cracking, or structural damage.

- 5.2.3 Any point on the covers shall withstand a 70 foot-pound impact administered with a 12 pound weight having a “C” tup (ASTM D-2444) without puncturing or splitting. The test shall be performed with the cover resisting upon a flat, rigid surface such as concrete or a 1” steel plate.
- 5.2.4 Fastening devices used to secure the cover to the box shall be capable of withstanding a minimum torque of 70 foot-pounds and with minimum straight pullout strength of 750 pounds. The torque test shall be performed on the box with the cover in place. The pullout test shall be performed on the box with the cover in place and the fastening devices torqued to the manufacturers recommended maximum value. Fastening devices, inserts, cover, and box shall not be damaged by the performance of these tests.
- 5.2.5 The fastening device in the box shall be of a “floating nut” style and be easily replaced.

6.0 MATERIALS

6.1 General

Materials used to manufacture nonconcrete enclosures shall be commercially available and of the highest quality consistent with their intended use.

6.2 Materials Qualification

6.2.1 Testing

Tests of materials used in the manufacture of nonconcrete enclosures shall be performed on specimens taken from finished product samples.

6.2.2 Control Specimens

Six specimens of same geometry shall be cut from the candidate sample. These specimens shall be designated as control specimens. The specimens shall be cut so as to provide coupons for tensile or flexural testing. Methods of testing for tensile or flexural strength shall be at the option of the manufacturer with the provision that the test shall be conducted in an identical manner for both control and test specimens for each property sought.

The control specimens shall be tested for ultimate flexural or tensile strength. The load versus deflection readings shall be taken, and the values of load and deflection at failure for each specimen shall be conducted in an identical manner for both control and test specimens for each property sought.

The control specimens shall be tested for ultimate flexural or tensile strength. The load versus deflection readings shall be taken, and the values of load and deflection at failure for each specimen shall be averaged to establish the control value.

6.2.3 Accelerated Service

Three specimens shall be taken from the candidate sample of finished product for testing under simulated accelerated service conditions. The test specimens shall be weighed and measured for length, width, and thickness. The specimens then shall be subjected to accelerated service exposure in accordance with ASTM Method D-7566, Procedure E, with the exception that specimen conditioning as described in Section 6.0 of this Method may be deleted. After the exposure cycle has been completed, the three test specimens shall be weighed, measured, and visually examined for changes. The specimens then shall be tested for failure under the identical conditions used for the control specimens. The average of the failure load and deflection values for the test specimens shall be determined.

6.2.4 Chemical Resistance

Twenty-seven specimens shall be taken from finished product candidate samples. These specimens shall be designated as test specimens. Each specimen shall be weighed and measured as in Section 6.2.3. Three specimens shall be exposed to each of the following chemical reagents in accordance with accordance with Section 7, Procedure 1, of ASTM Method D-543. (Use Standard Laboratory Atmosphere and seven days for all tests.)

<u>Chemical</u>	<u>Concentration in Water Solution</u>
Sodium Chloride	5%
Sulfuric Acid	0.1 N
Sodium Carbonate	0.1 N
Sodium Sulfate	0.1 N
Hydrochloric Acid	0.2 N
Sodium Hydroxide	0.1 N
Acetic Acid	5%
Kerosene	Per ASTM D-543
Transformer Oil	Per ASTM D-543

After the exposure cycle has been completed, each specimen shall be dried, weighted, measured, and tested in accordance with Section 6.2.2. The average failure loads and deflections for each set of three specimens from each reagent exposure shall be computed and recorded as test values. Each specimen shall be visually examined and any changes in appearance are to be noted.

6.2.5 Simulated Sunlight Exposure

Three specimens shall be prepared, weighed, and measured in accordance with Sections 6.2.2 and 6.2.3. The specimens shall be tested in accordance with ASTM G-53 with a U.V.A. 340 lamp. After exposure, the specimen shall be measured, weighed, visually examined for changes, and tested in accordance with Section 6.2.2.

6.2.6 Water Absorption

Three specimens shall be taken as in Section 6.2.2 and weighed and measured. The specimens shall be exposed to water environments in accordance with ASTM D-570, Sections 6.0, 7.1, and 7.5. After exposures, the specimens shall be weighed, measured, visually examined for changes, and tested in accordance with Section 7.2.2.

6.2.7 Flammability

Flammability tests for all material on exposed surfaces shall be conducted on three specimens 1" wide x 4" long x finished product thickness. Each specimen shall be held in a horizontal position, is ignited on one end, and the rate of burning along the length determined.

6.3 Acceptance Criteria

Materials for non-concrete enclosures shall be determined to be acceptable if each of the following criteria is met. For Sections 6.2.3, 6.2.4, 6.2.5, and 6.2.6: retention of 75 percent of the control specimen values for load or deflection; no more than 2 percent change in weight.

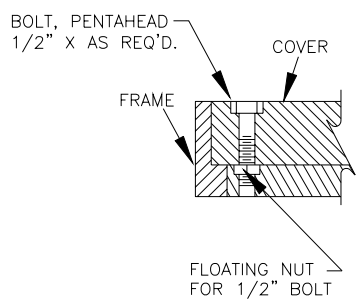
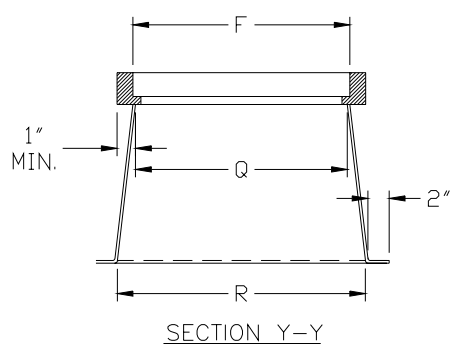
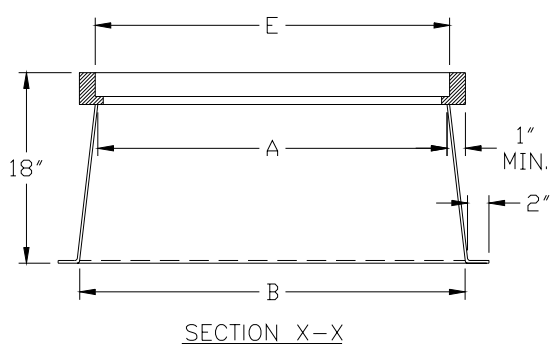
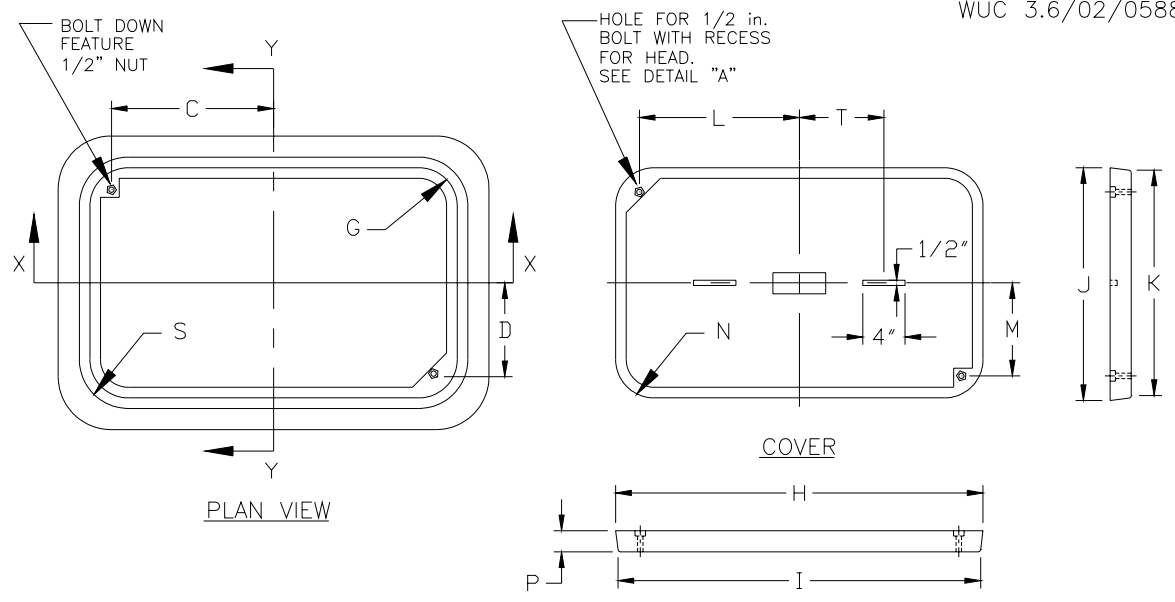

NOTE:
SEE FIGURE 4 FOR
BOX DIMENSIONING.

DETAIL "A"
COVER BOLT-DOWN
DETAIL

FIGURE 1
BODY AND COVER
(17" X 30" BOX SHOWN)

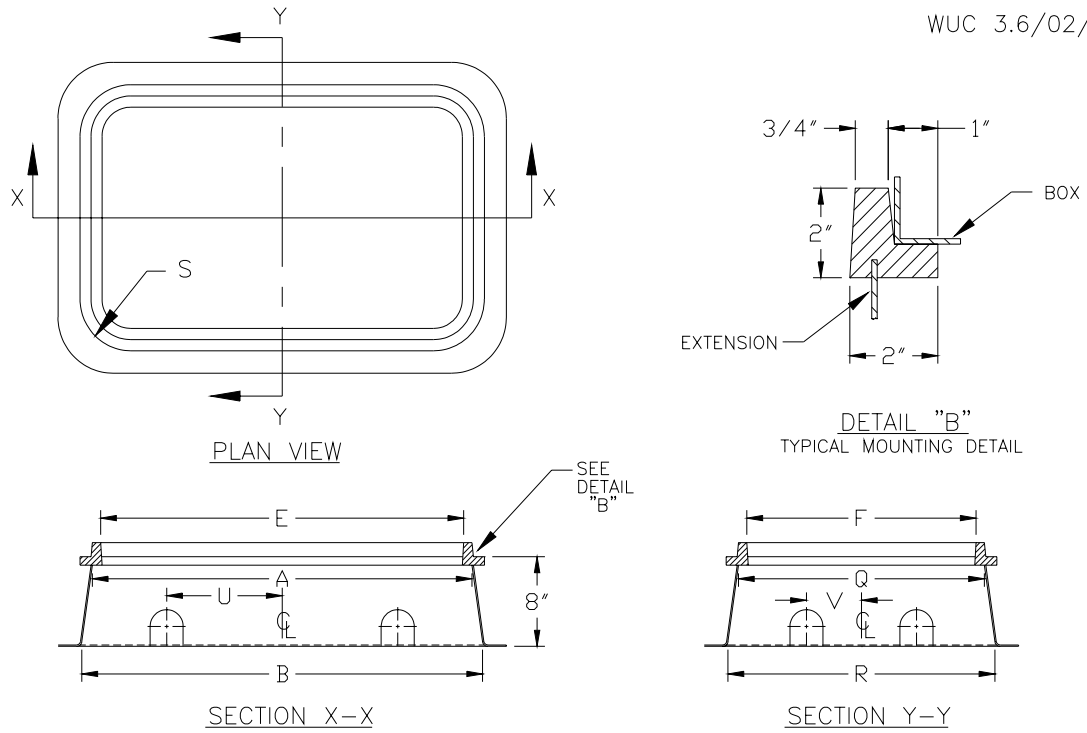

FIGURE 2
8" EXTENSION

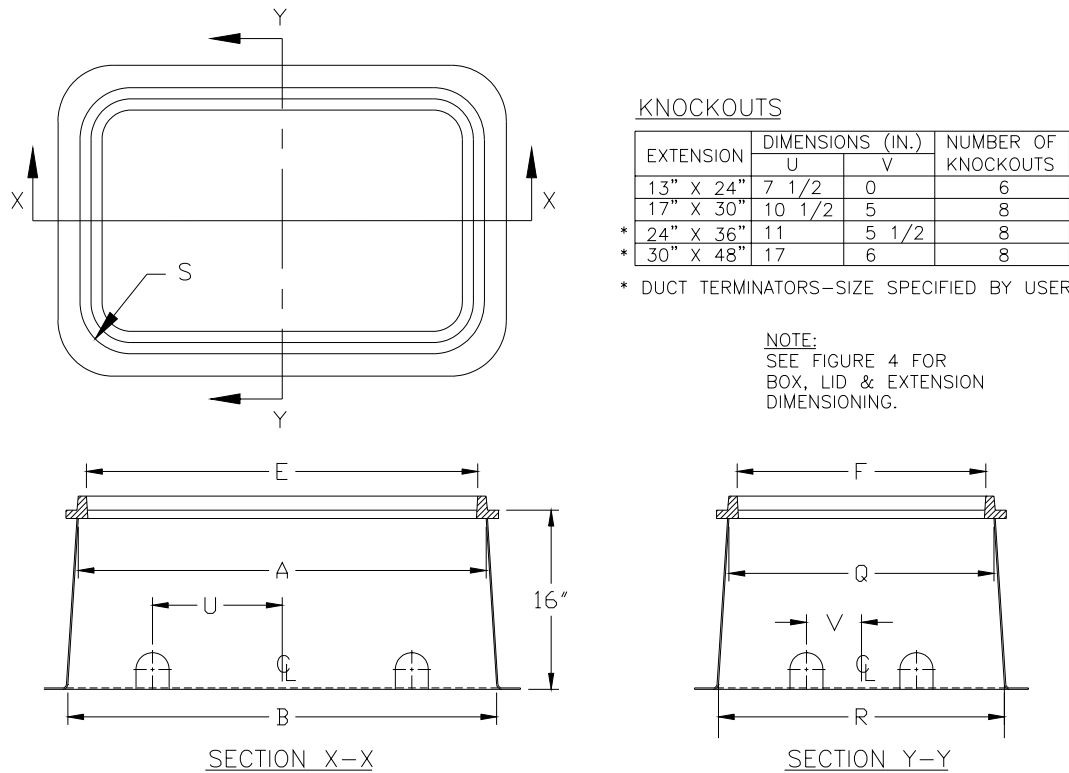

FIGURE 3
16" EXTENSION

BOX SIZE	DEPTH	DESCRIPTION	DIMENSIONS (INCHES) -- BOX COMPONENTS																	
			A	B	C	D	E	F	G	H	I	J	K	L	M	N	P	Q	R	S
13" X 24"	18"	BODY	26	29 1/2	9 7/8	5 1/8	23 1/2	14	1 1/2	-	-	-	-	-	-	-	16 1/2	20	4 5/8	-
	8"	EXTENSION	28 1/2	30	-	-	29 1/4	19 3/4	-	-	-	-	-	-	-	-	19	20 1/2	4 1/2	-
	16"	COVER	28 1/2	31 3/4	-	-	29 1/4	19 3/4	-	-	-	-	-	-	-	-	19	22 1/4	4 1/2	-
17" X 30"	18"	BODY	33 1/4	36 3/4	13 1/4	6 3/4	30 3/4	17 3/4	1 1/2	-	-	-	-	-	-	-	20 1/4	23 3/4	4 5/8	-
	8"	EXTENSION	35 3/4	37 1/4	-	-	36 1/2	23 1/2	-	-	-	-	-	-	-	-	22 3/4	24 1/4	4 1/2	-
	16"	COVER	35 3/4	39	-	-	36 1/2	23 1/2	-	-	-	-	-	-	-	-	22 3/4	26	4 1/2	-
24" X 36"	18"	BODY	39 1/8	42 1/8	15 9/16	9 3/4	35 7/8	24 1/4	5 1/8	-	-	-	-	-	-	-	27 1/2	30 1/2	8 3/4	-
	8"	EXTENSION	41 1/8	42 5/8	-	-	41 7/8	30 1/4	-	-	-	-	-	-	-	-	29 1/2	31	8 5/8	-
	16"	COVER	41 1/8	44 3/8	-	-	41 7/8	30 1/4	-	-	-	-	-	-	-	-	29 1/2	32 3/4	8 5/8	-
30" X 48"	18"	BODY	51 1/8	54 1/8	21 5/16	12 9/16	47 7/8	30 3/8	5 1/8	-	-	-	-	-	-	-	35 5/8	36 5/8	8 3/4	-
	8"	EXTENSION	53 1/8	54 5/8	-	-	53 7/8	36 3/8	-	-	-	-	-	-	-	-	35 5/8	37 1/8	8 5/8	-
	16"	COVER	53 1/8	56 3/8	-	-	53 7/8	36 3/8	-	-	-	-	-	-	-	-	35 5/8	38 7/8	8 5/8	-
ALL	-	PENTAHEAD BOLT 1/2" X AS REQ D-SS	-	-	-	-	-	-	-	47 5/8	47 1/8	30 1/8	29 5/8	21 5/16	12 9/16	5	3	-	-	15

FIGURE 4
BOX COMPONENTS
NON-CONCRETE BOXES (INCIDENTAL TRAFFIC)