

WESTERN UNDERGROUND COMMITTEE

GUIDE 2.12A (2.12A/01/0194)

PADMOUNTED 3 PHASE LIVE FRONT CAPACITOR BANK

NOTE: This "Guide" summarizes the opinions, recommendations, and practices of the Western Underground Committee members and is issued only to assist these members in preparing their own specifications, or in making recommendations to specification agencies. Thus, this "Guide" may not reflect the complete requirements of each individual utility and is not binding upon them.

1.0 SCOPE

This guide outlines the electrical and mechanical requirements for a three phase switched padmounted live front, metal enclosed, free standing, and front access operation capacitor bank.

2.0 GENERAL

2.1 This unit is constructed in two (2) distinct compartments. The control compartment shall comprise the control devices. The main compartment shall be comprised of the high voltage equipment. (Capacitors, fuses, switches, potential transformer, and other high voltage equipment as may be specified.)

2.2 See Figures 1 to 4, page 8, for general design requirements.

2.3 Referenced Specifications
(Latest edition unless otherwise indicated)

ANSI C57.12.28 "Switchgear and Transformers – Pad-Mounted Equipment – Enclosure Integrity"

ANSI/IEEE 18 "Standard for Shunt Power Capacitors"

ANSI C37.66 "Standard Requirements for Oil-Filled Capacitor Switches"

ANSI MH1.1.2 "Pallet Definitions and Terminology"

ANSI C37.72 "American National Standard for manually-operated, dead-front padmounted switchgear with load interrupting switches and separable connectors for alternating-current systems"

3.0 RATINGS

- 3.1 Voltage: 15 kV, maximum, rated 95 kv BIL.
- 3.2 Size/Capacitors: 1200 kVar – 400 kVar maximum per phase using 200 kVar single-phase units. The capacitor units shall have one/two high voltage bushings. Capacitors shall comply with ANSI/IEEE 18.
- 3.3 Potential Transformer: 120 volt secondary – 500VA, minimum.
- 3.4 Switches: Continuous and loadbreak rating 200 amp, 15 kV, 90° leading power factor. Units may be insulated with oil/vacuum/other gasses. Units may be single/three phase operation. Units shall be capable of 10,000 on-off cycles under the continuous and loadbreak rating. Switches shall be provided with a visible manually operating handle. Switches shall comply with ANSI C37.66.
- 3.5 Bus Work: All bussing shall be capable of withstanding the short time currents for class 1/2/3, as defined by ANSI C37.72.

4.0 CONSTRUCTION

- 4.1 Cabinet: The maximum dimensions shall be as specified by user. The cabinet shall be weather resistant, and comply with current ANSI C57.12.28 for tamper resistance.
- 4.2 Construction of unit shall be such that it can be transported, lifted, and set into place without damage to, or distortion of, any portion of the cabinet or contents.
- 4.3 All welds shall be ground smooth.
- 4.4 The roof shall be crowned to provide rigidity and drainage.
- 4.5 Two/Four permanent/removable lifting points shall be provided which are capable of lifting and setting the complete unit in a level fashion, using a sling with hooks or clevises. If removable, the lifting provisions shall be capable of being utilized as pad anchor brackets.

- 4.6 A continuous $\frac{3}{4}$ inch, minimum, metal flange shall be provided for anchoring the cabinet to a pad. The base shall be corrosion resistant.
- 4.7 Pentahead bolts complying with ANSI C57.12.28 shall be located on all external access points. The pentahead latching shall be made of corrosion resistant material, and shall be field replaceable in the event of failure. Provisions shall be made for padlocking all external pentahead bolt locations.
- 4.8 All hinges shall be lift off design, welded to both attachment points. Hinge and pin shall be stainless steel. Permanent doorstops shall be provided to hold the door(s) in an open position of both 90 and 110 degrees.
- 4.9 For top hatch units, the hatch shall be hinged to provide a swing angle of 180 degree from the closed position to an open position resting on top of the termination/control compartment.
- 4.10 A method to prevent the accumulation of moisture on the inside top of the enclosure shall be employed.
- 4.11 A means to facilitate removal of the capacitor units shall be provided.

5.0 FINISH

- 5.1 All metal surfaces of the cabinet both internal and external shall be coated with materials and methods, which comply with the current requirements of ANSI C57.12.28.
- 5.2 Color shall be green (Munsell 7GY3.29/1.5) / light gray (ANSI 70, MUNSELL 5BG7.0/0.4) or as specified.
- 5.3 Vinyl paint is not acceptable.

6.0 BARRIERS

- 6.1 Barriers shall be constructed of a non-hygroscopic insulating material and shall be capable of withstanding 60 Hz, 35 kV, for one minute. The minimum clearance, barrier to any live part, shall be 3 inches.
- 6.2 Transparent removable barriers shall be used to guard the live parts located behind the doors.

7.0 ELECTRICAL REQUIREMENTS

- 7.1 Provisions for over current and inrush restraint devices shall be provided, as required by the user. The devices may be located at the supply cable terminating point (front end protection) or at each capacitor tank (back end protection).
- 7.2 The primary of the potential transformer may be protected by connection to the load side of the right most over current device (typical for front end protection) or by a separate over current device (typical of back end protection).
- 7.3 Capacitors shall be connected grounded/ungrounded WYE or DELTA.
- 7.4 The connections to the capacitor tanks shall allow for the removal and replacement of a single unit without disconnecting other units.
- 7.5 The connectors used shall have a midrange equal to the wire diameter used.
- 7.6 Ground lugs or provisions for them shall be provided in both the termination/control and high voltage compartments.

8.0 CONFIGURATION

- 8.1 Two front door(s) shall be provided. The right most doors shall be the first operable, providing access to the control compartment, and pentahed head bolt(s) securing the second door. The second door shall provide access to the high voltage compartment. The rear door(s) or top hatch shall provide clear access to the high voltage section, to allow removal and replacement of any component.
- 8.2 The control meter socket shall be mounted on the inside of the right most doors. The centerline of the meter socket shall be a minimum of 38 inches above the base of the unit, and a minimum of 10 inches from the hinged end of the door. A grounding conductor shall be provided, for connection to the control enclosure.

- 8.3 The junction box shall be mounted on the right hand side of the control/termination compartment, a minimum of 28 inches above the base of the unit. A flexible conduit shall connect between the junction box and the meter socket. The terminal block shall be a two-screw type, capable of seating a minimum #8 AWG connector.
- 8.4 The control wiring shall be a minimum #14 AWG, 600 volt, insulated, stranded copper cable suitable for exposure to oil and/or water, and 90° C operation. The color code shall be as specified by user.
- 8.5 The left most supply cable terminating point shall be terminating points shall be spaced 13 inches apart.

9.0 OPERATING CONDITIONS

The unit shall be designed to operate within an ambient temperature specified by the purchaser, without exceeding all the devices temperature rise limits.

10.0 TESTING

- 10.1 Each completed unit, with the capacitors & potential transformer disconnected, shall pass a 35 kV, one minute withstand test.
- 10.2 The individual capacitors shall be tested using a capacitance meter. The measured capacitance of a 200kVar capacitor shall not be more than 12.28 microfarads or less than 9.21 microfarads. Either the manufacturer of the capacitor or the fabricator of the padmounted capacitor bank may perform this test.
- 10.3 The control scheme shall be tested to verify the correct wiring.
- 10.4 One certified copy of all test and inspection reports should be sent to the purchaser upon delivery of the unit.

11.0 NAMEPLATE

11.1 A nameplate shall be permanently attached to the interior of the termination/control compartment. The nameplate shall as a minimum contain the following information:

- a) Manufacturer
- b) Month and year of manufacture
- c) Serial Number
- d) kVar rating of bank
- e) Voltage rating of bank
- f) Weight
- g) No PCB (at time of manufacture)

11.2 Each oil filled component's nameplate shall also be marked that certifies the oil was classified no PCB's or less than 2 P.P.M. PCB's according to the Federal Regulations at the time of manufacture.

12.0 SHIPPING

12.1 The finished unit shall be packaged and internally braced so as to arrive free of external scratches, distorted metal, and any internal damage. Any component showing evidence of leaking will not be accepted.

12.2 The finished unit shall be securely strapped to a double flush deck pallet (ANSI MH1.1.2). Strapping must be external to the unit and cushioned to prevent damage to the paint coating. Internal bolting to the pallet in areas not within the first one-foot from the termination/control compartment door is unacceptable.

12.3 The pallet shall be designed for fork entry only from the heavy side (back) of the unit. These fork entries shall face the outside of the shipping truck to allow for removal with a forklift from the sides of the flatbed trailer.

13.0 LABELING

13.1 NEMA standard bilingual "MR OUCH" WARNING shall be located on the outside surface of the door(s). NEMA standard bilingual "MR OUCH" DANGER shall be located on the inside surface of the door(s), or barriers.

- 13.2 The terminating points shall be identified “A”, “B”, “C” left to right when facing the front of the unit.
- 13.3 A label showing a 3-line wiring diagram shall be located adjacent to the control meter socket.

14.0 QUOTATIONS

- 14.1 Quotations shall include one complete set of drawings showing the design and construction of the bank. Bidders shall identify all exceptions to their quotation. In addition, the design losses of the capacitors at rated voltage and frequency for the range of ambient temperatures of 0 through 46° C and the capacitors stress, defined by the following shall be included:

$$\text{Capacitor Stress} = \frac{\text{Voltage of unit} / \text{Number of series groups}}{\text{Film thickness}}$$

POT. TRANSFORMER .5 KVA
7200/120V. (IF 2 BUSHING
TRANSFORMER IS USED
PRIMARY NEUTRAL BUSHING
MUST BE GROUND.)

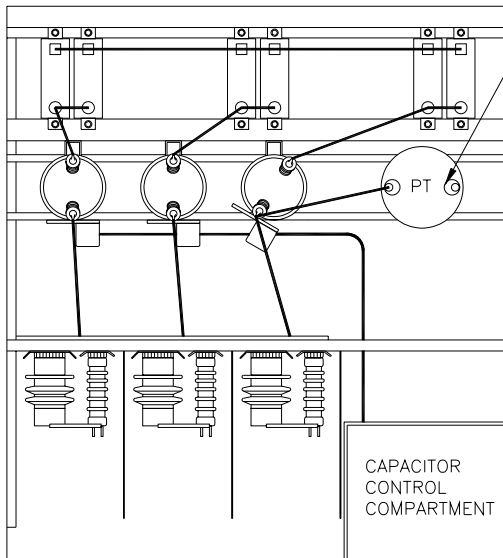

TOP VIEW
FIGURE 1

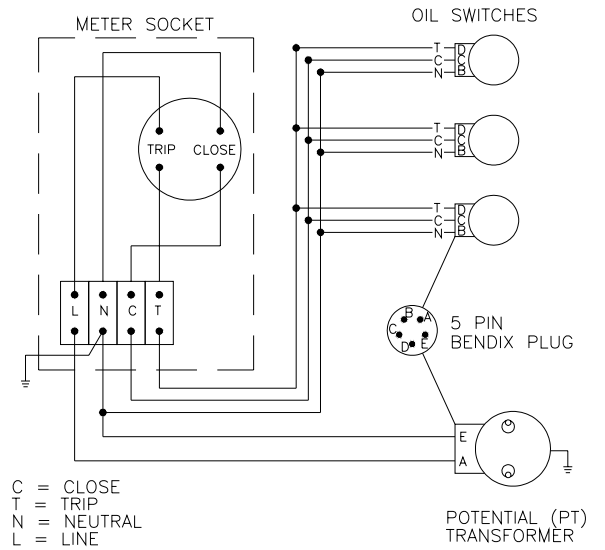

CONTROL SCHEMATIC
FIGURE 4

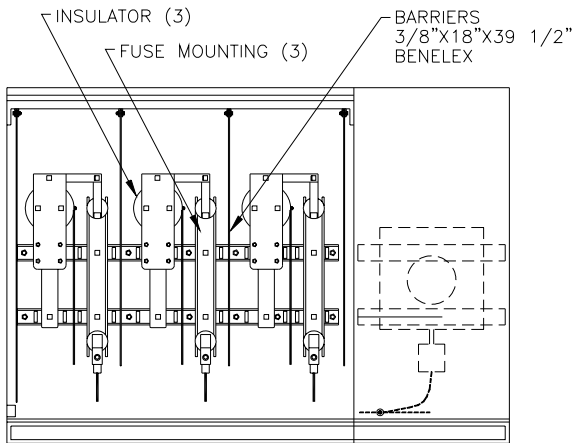

FRONT VIEW
FIGURE 2

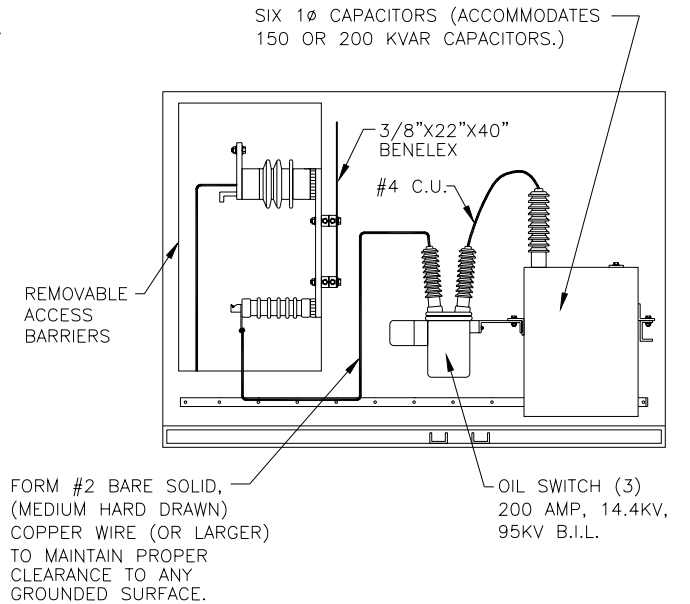

SIDE VIEW
FIGURE 3

CAPACITOR
GENERAL
DESIGN REQUIREMENTS